

BBF5 Ba k_ WdU Bae f[thWF W_ bWdSfgdW5 aWxUW f

BF5e

K:@F

BBF5

:!A



Bae f[thWF W_ bWdSfgdW Ua WxUW f VVhLUW e t S e a] : ai ` Se dVZ eWfST W XgeV e t b d h[V [Y a hWZ UgdW f b d a fWU f a ` X a d W W U f d a [U U d U g f e S : V VVhLUW e z F Z W d W e j e f S : U W a X B F 5 e d e W e Se f z W f W _ b W d S f g d W d e W e z l [f z f z e X W S f g d W f z W h S g W U Z S : Y W a X d W e j e f S : U W j e : a f a T h g e i Z W f z W e S X W U g d W f b S e e W e t f z W d W e j e f S : U W h S g W U Z S : Y W e V d S e f U S * i Z W S T : a d _ S ^ U g d W f b S e e W e t f z l e d W S U Z W e f z W b g d a e W a X [[Y S T : a d _ S ^ U g d W f i f z W d W e j e f S : U W h S g W i [^ d W e W f S g f a _ S f U S * i Z W f z W S T : a d _ S f k l e W _ [S f W S : V f W _ b W d S f g d W d W f g d e f a S e S X W W h W z K : @ F a X W e S b a k _ W d U b a e f [t h W f W _ b W d S f g d W U a W x U W f / B B F 5 f i S e S : a h W e z U g d W f b d a f W U f a ` V V h L U W f z S f U a g V d W g U W f z W U a e f e a X i S d S : f k S : V _ S f f W S : U W z : f j e S : [V W S ^ U Z a [U W X a d W e g j b _ W f i [f z X W e g W f S T : a d _ S ^ a h W e z U g d W f X a i [Y S d W S z B B F 5 a X W g e W [U a : e g _ W d W W U f d a : U e t b a i W d f W e t f W W U a _ _ g : [U S f f a : e t : ! A U a : ` W U f a d e t b d a U W e U a : f d a : S : V _ W [U S ^ W e g j b _ W f z

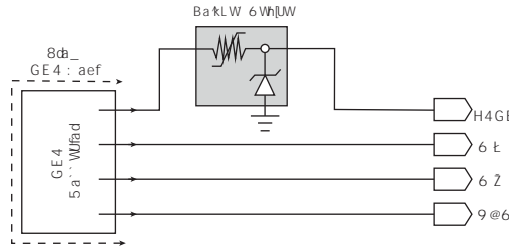

DSVJS ^MSVW eWdW e

- ▲ (" " HVU B d a f W U f a ` V V h L U W e g b f a (" " HVU
- ▲ 3 h W k Z [Y ` Z a V U g d W f
- ▲ > a i f d b f a Z Z a V U g d W f d S f j a
- ▲ > a i d S e j e f S : U W

E g X S U W _ a g ` f V V h L U W e

- ▲ E _ S ^ h a g _ W W W e [Y `
- ▲ > a i Z a V U g d W f
- ▲ H W k X S e f f d b U g d W f
- ▲ > a i d W e [f S : U W



K:@F

EgXUW_ ag` fVWhUWé,

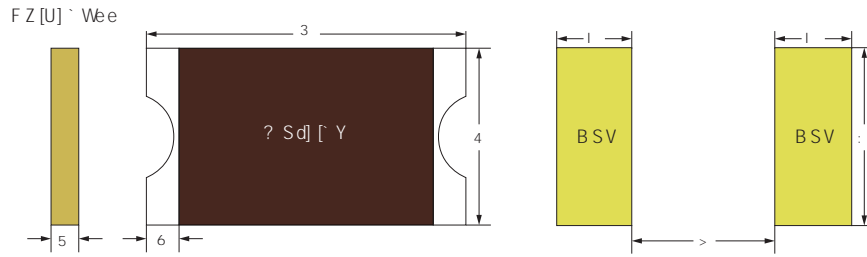

7 WUfdUS ^5 ZScSUWdfe]Ue

Product model	A	B	C	D	W	H	L
	Max	Max	Max	Min	±0.1	±0.1	±0.1
E? 6" (" %	#Z'	#Z'	#Z"	"Z#'	#Z'	#Z'	"Z'
E? 6" *''	\$Z\$"	#Z"	#Z"	"Z\$"	#Z'	#Z'	#Z\$
E? 6#\$*(%Z"	#Z"	#Z\$"	"Z#'	#Z'	#Z+	\$Z'
E? 6#\$#\$"	%Z&%	\$Z"	#Z&"	"Z%'	#Z'	\$Z'	\$Z'
E? 6#\$#\$	&Z)%	%Z&#	#Z\$"	"Z%'	#Z)'	%Z\$	%Z\$
E? 6\$#\$"	'Z&&	&Z+%'	#Z#"	"Z%'	#Z'	&Z('	%Z&
E? 6\$+\$")Z+*	'Z&&	#Z#"	"Z%'	\$Z%'	'Z('	'Z#

D WdWfST WBF 5 E Ž " (" % E WdWd

7 WdUqUS ^5 ZSdSUWd fUe

Products model	Vmax (dc)	Imax (A)	Ihold @ 25 (A)	Itrip @ 25 (A)	Pd Max (W)	Max Time to trip		Resistance	
						Current (A)	Time (Sec)	Rmin (Ω)	R1max(Ω)
E? 6" (" %Ž" #"	#"	&"	" #"	" Ž"	" Ž	#Ž"	" Ž+ "	" Ž+ "	(Ž "
E? 6" (" %Ž" \$"	+	&"	" Ž"	" Ž "	" Ž	#Ž"	" Ž "	" Ž "	%Ž "
E? 6" (" %Ž" \$'	+	&"	" Ž'	" Ž '	" Ž	*Ž"	" Ž *	" Ž "	%Ž "
E? 6" (" %Ž" %	(&"	" Ž"	" Ž)'	" Ž	*Ž"	" Ž#"	" Ž# "	#Ž# "
E? 6" (" %Ž" " "	(&"	" Ž "	#Ž "	" Ž	*Ž"	" Ž#"	" Ž# "	" Ž "
E? 6" (" %Ž")'	(&"	" Ž)'	#Ž# "	" Ž	*Ž"	" Ž#"	" Ž ("	" Ž# "
E? 6" (" %Ž" #""	(&"	#Ž "	\$Ž "	" Ž	*Ž"	" Ž#"	" Ž & "	" Ž# "

FZWd_ S^6 WdSfj` 5 ZSdZ: Za V

Model									
	-40	-20	0	25	40	50	60	70	85
E? 6" (" %Ž" #"	" #%"	" #%"	" #%"	" #"	" Ž "	" Ž)	" Ž (" Ž)	" Ž %
E? 6" (" %Ž" \$"	" Ž)	" Ž'	" Ž%"	" Ž"	" Ž#)	" Ž#&	" Ž#"	" Ž#"	" Ž)
E? 6" (" %Ž" \$'	" Ž#"	" Ž#"	" Ž)	" Ž'	" Ž#"	" Ž#"	" Ž# (" Ž#&	" Ž#"
E? 6" (" %Ž" %	" Ž#)	" Ž#"	" Ž#"	" Ž#"	" Ž#"	" Ž# (" Ž#&	" Ž#"	" Ž#&
E? 6" (" %Ž" " "	" Ž(" Ž +	" Ž &	" Ž "	" Ž#"	" Ž#)	" Ž#&	" Ž#"	" Ž#"
E? 6" (" %Ž")'	" Ž+ "	" Ž (" Ž #	" Ž)'	" Ž (\$	" Ž #	" Ž# (" Ž#"	" Ž#)
E? 6" (" %Ž" #""	#Ž#"	#Ž#"	#Ž# "	#Ž "	" Ž "	" Ž &	" Ž "	" Ž)	" Ž# "

BBF5

D WeWfST WBF 5 E Ž " * " ' E WdWe

7 WUfdUS ^5 Z SdSUFWde fUe

Products model	Vmax (dc)	Imax (A)	Ihold @ 25 (A)	Itrip @ 25 (A)	Pd Max (W)			Rmin (Ω)	R1max(Ω)
						Current (A)	Time (Sec)		
E? 6"*** Ž" #"	#'	#""	" Ž#"	" Ž%"	" Ž	" Ž	#Ž "	#Ž ""	(Ž ""
E? 6"*** Ž" S"	+1#'	#""	" ŽS"	" Ž "	" Ž	*Ž	" Ž \$	" Ž("	%Ž ""
E? 6"*** Ž" %	(#""	" Ž%	" Ž)	" Ž	*Ž	" Ž#"	" ŽS "	#ŽS ""
E? 6"*** Ž" "	(#""	" Ž "	#Ž "	" Ž	*Ž	" Ž#"	" Ž# "	" Ž" "
E? 6"*** Ž")'	(&* Ž	" Ž)	#Ž "	" Ž(*Ž	" ŽS"	" Ž +"	" Ž%'
E? 6"*** Ž#""	(1* Ž	#""	#Ž "	#Ž+'	" Ž(*Ž	" Ž%"	" Ž ("	" ŽS%"
E? 6"*** Ž##"	(#""	#Ž#"	SŽS"	" Ž(*Ž	" Ž%"	" Ž ("	" ŽS#"
E? 6"*** Ž#S'	(#""	#ŽS'	SŽ "	" Ž(*Ž	" Ž("	" Ž %"	" Ž#&"

F ZWd_ S^6 WdSfpa` 5 ZSdZ;Za V

Model										
	-40	-20	0	25	40	50	60	70	85	
E? 6"*** Ž" #"	" Ž ŽS " Ž#&	" Ž# \$	" Ž# #	" Ž#"	" Ž +	" Ž)	" Ž (" Ž '	" Ž %"	" Ž
E? 6"*** Ž" S"	" ŽS"	" ŽS'	" ŽS%"	" ŽS"	" Ž#)	" Ž#&	" Ž# \$	" Ž#"	" Ž)	
E? 6"*** Ž" %	" Ž&)	" Ž&&	" Ž%+	" Ž%"	" Ž%"	" ŽS)	" ŽS&	" ŽS"		

D WdWfST WBF 5 E Z # \$" (E WdWd

7 WdUdUS ^5 ZSdSUWdUe fUe

Products model	Vmax (dc)	Imax (A)	Ihold @ 25 (A)	Itrip @ 25 (A)	Pd Max (W)	Max Time to trip		Resistance	
						Current (A)	Time (Sec)	Rmin (Ω)	R1max(Ω)
E? 6#S" (Z" ""	("	#""	" Z' "	" Z#'	" Z&	" Z%	#Z "	%Z(""	' " Z "
E? 6#S" (Z" #"	("	#""	" Z#""	" Z\$'	" Z&	" Z	#Z "	#Z(""	#' Z "
E? 6#S" (Z" #S	("	#""	" Z#S'	" Z\$+"	" Z(#Z'	" Z\$"	#Z' ""	#' Z "
E? 6#S" (Z" \$"	\$&	#""	" Z\$""	" Z&("	" Z(*Z'	" Z* "	" Z% "	\$Z' ""
E? 6#S" (Z" \$'	#(#""	" Z\$' "	" Z "	" Z(*Z'	" Z* "	" Z% "	\$Z' ""
E? 6#S" (Z" %	(!#(#""	" Z% "	" Z)'	" Z(*Z'	" Z#"	" Z\$' "	#Z% "
E? 6#S" (Z" ""	(!#(!S&	#""	" Z' ""	#Z' "	" Z(*Z'	" Z#"	" Z#' "	" Z) ""
E? 6#S" (Z")'	(!#(#""	" Z) ' "	#Z' "	" Z(*Z'	" Z\$"	" Z' +"	" Z' ""
E? 6#S" (Z#""	(#""	#Z' "	#Z' "	" Z(*Z'	" Z% "	" Z' "	" Z\$) "
E? 6#S" (Z##"	(#""	#Z#"	\$Z' "	" Z(*Z'	" Z% "	" Z' "	" Z\$) "
E? 6#S" (Z#' "	(!#%Z\$	#""	#Z' "	%Z' "	" Z "	*Z'	#Z' "	" Z' &"	" Z#% "
E? 6#S" (Z\$""	(#""	\$Z' "	%Z' "	" Z(*Z'	#Z' "	" Z' #"	" Z' ""

BBF5

FZWd_ S^6 WdSfga` 5 ZSdZ:Za V

Model										
	-40	-20	0	25	40	50	60	70	85	
E? 6#S" (Z" #"	" Z#&'	" Z%&	" Z##'	" Z#""	" Z' "	" Z)'	" Z)	" Z(" Z' "	
E? 6#S" (Z" #S	" Z#""	" Z#(" Z#&	" Z#S'	" Z' #"	" Z' +"	" Z' "	" Z)	" Z' "	
E? 6#S" (Z" \$"	" Z%&	" Z% "	" Z\$&	" Z\$"	" Z#)"	" Z#% "	" Z#"	" Z' +"	" Z)	
E? 6#S" (Z" \$'	" Z% "	" Z%&	" Z\$+"	" Z\$'	" Z\$S	" Z\$"	" Z#)"	" Z#'	" Z#S	
E? 6#S" (Z" %	" Z' "	" Z&'	" Z&"	" Z% "	" Z% "	" Z\$)	" Z\$&	" Z\$#	" Z#'	
E? 6#S" (Z" ""	" Z) #	" Z(&	" Z)	" Z "	" Z&S	" Z%+	" Z% "	" Z/#"	" Z\$'	
E? 6#S" (Z")'	#Z#&	#Z' #	" Z' "	" Z)'	" Z(" Z' +"	" Z' &	" Z&+"	" Z&#	
E? 6#S" (Z#""	#Z&'	#Z/#	#Z#'	#Z' "	" Z' &	" Z) "	" Z(+"	" Z(#	" Z&*	
E? 6#S" (Z##"	#Z&+"	#Z% "	#Z# +	#Z#"	" Z' +"	" Z' "	" Z) &	" Z("	" Z \$	
E? 6#S" (Z#' "	\$Z#"	#Z+&	#Z) S	#Z' "	#Z\$*	#Z#)"	#Z' (" Z+(" Z) "	
E? 6#S" (Z\$""	\$Z' "	\$Z(\$Z% "	\$Z' "	#Z) *	#Z(#Z%&	#Z\$#	#Z' "	



D WeWfST WBF 5 E Ž # \$ # " E WdWe

7 WUfdUS ^5 Z SdSUFWdfe flUe



Products model	Vmax (dc)	Imax (A)	Ihold @ 25 (A)	Itrip @ 25 (A)	Pd Max (W)	Max Time to trip		Resistance	
						Current (A)	Time (Sec)	Rmin (Ω)	R1max(Ω)
E ? 6 # \$ # " Z " " "	%	# " "	" Z ' "	" # # " "	" Z ("	" Z % "	# Z " "	\$ Z " "	' " Z "
E ? 6 # \$ # " Z " # " "	%	# " "	" # # " "	" Z S " "	" Z ("	" Z " "	" Z ("	" Z " "	# ' Z "
E ? 6 # \$ # " Z " S " "	%	# " "	" Z S " "	" Z & " "	" Z ("	" Z " "	" Z S "	" Z & " "	' Z "
E ? 6 # \$ # " Z " % "	(# " "	" Z % "	" Z) " "	" Z ("	" Z " "	" Z S " "	" Z S " "	# Z % "
E ? 6 # \$ # " Z " " " "	# % Z S	# " "	" Z " "	# Z " "	" Z ("	" Z " "	" Z # " "	" Z # " "	" Z + " "
E ? 6 # \$ # " Z ") ' "	(# " "	" Z) ' "	# Z " "	" Z ("	" Z " "	" Z # " "	" Z) "	" Z & " "
E ? 6 # \$ # " Z # # " "	(# " "	# Z # " "	\$ Z S " "	" Z ("	" Z " "	" Z % "	" Z ' "	" Z S # "
E ? 6 # \$ # " Z # " " "	(# " "	# Z " "	% Z " "	" Z ("	" Z " "	" Z " "	" Z % "	" Z # # "

F ZWd_ S ^6 WdSfja ` 5 Z SdZ : Za V

Model									
	-40	-20	0	25	40	50	60	70	85
E ? 6 # \$ # " Z " " " "	" Z + "	" Z) "	" Z ("	" Z ' "	" Z & "	" Z & "	" Z % "	" Z % "	" Z S "
E ? 6 # \$ # " Z " # " "	" Z # ("	" Z # & "	" Z # S "	" Z # " "	" Z + "	" Z) "	" Z ("	" Z ' "	" Z % "
E ? 6 # \$ # " Z " S " "	" Z S + "	" Z S ("	" Z S S "	" Z S " "	" Z # ("	" Z # & "	" Z # % "	" Z # # "	" Z + "
E ? 6 # \$ # " Z " % "	" Z &) "	" Z & ' "	" Z & " "	" Z % "	" Z % % "	" Z S + "	" Z S & "	" Z S # "	" Z # + "
E ? 6 # \$ # " Z " " " "	" Z) ("	" Z () "	" Z + "	" Z " "	" Z & % "	" Z & " "	" Z () "	" Z S \$ "	" Z S + "
E ? 6 # \$ # " Z ") ' "	# Z " "	" Z +) "	" Z ("	" Z) ' "	" Z (& "	" Z + "	" Z & "	" Z & " "	" Z & " "
E ? 6 # \$ # " Z # # " "	# Z (+ "	# Z & + "	# Z S + "	# Z # " "	" Z + " "	" Z) ("	" Z (' "	" Z) "	" Z & % "
E ? 6 # \$ # " Z # " " "	\$ Z # % "	# Z + S "	# Z) # "	# Z " "	# Z S ("	# Z # & "	# Z # "	" Z + "	" Z) # "



D WdWfST WBF 5 E Z #* # \$ E WdWd

7 WdUqUS ^5 ZScSUWdfe fUe

Products model	Vmax (dc)	Imax (A)	Ihold @ 25 (A)	Itrip @ 25 (A)	Pd Max (W)	Max Time to trip		Resistance	
						Current (A)	Time (Sec)	Rmin (Ω)	R1max(Ω)
E? 6#*#\$Z" #"	%!("	#" "	" Z#" "	" Z%" "	" Z' "	" Z "	#Z "	" Z' "	#' Z' "
E? 6#*#\$Z" #&	("	#" "	" Z#& "	" Z/& "	" Z' "	#Z "	#Z#' "	" Z("	(Z' "
E? 6#*#\$Z" \$"	%!("	#" "	" Z\$" "	" Z& "	" Z' "	*Z "	" Z\$" "	" Z% "	' Z' "
E? 6#*#\$Z" %"	% "	#" "	" Z%" "	" Z' "	" Z' "	*Z "	" Z#" "	" Z\$" "	%Z' "
E? 6#*#\$Z" ' "	#' 1%&!("	#" "	" Z' "	#Z' "	" Z' "	*Z "	" Z#' "	" Z#' "	#Z' "
E? 6#*#\$Z")'	#%Z\$1%& "	#" "	" Z)'	#Z' "	" Z' "	*Z "	" Z\$" "	" Z' + "	" Z&' "
E? 6#*#\$Z#"	*!#(!&1%& "	#" "	#Z#" "	\$Z\$" "	" Z' "	*Z "	" Z%" "	" Z' "	" Z\$" "
E? 6#*#\$Z#&'	#("	#" "	#Z\$' "	\$Z' "	" Z' "	*Z "	" Z&' "	" Z' "	" Z#&' "
E? 6#*#\$Z#' "	*!#(!& "	#" "	#Z' "	%Z' "	" Z' "	*Z "	" Z' "	" Z' & "	" Z#("
E? 6#*#\$Z#("	* "	#" "	#Z' "	\$Z' "	" Z' "	*Z "	#Z' "	" Z' % "	" Z#% "
E? 6#*#\$Z\$' "	*!#("	#" "	\$Z' "	&Z' "	" Z' "	*Z "	\$Z' "	" Z' \$ "	" Z#' "
E? 6#*#\$Z\$("	* "	#" "	\$Z' "	' Z' "	" Z' "	*Z "	\$Z' "	" Z' # "	" Z' "
E? 6#*#\$Z% "	* "	#" "	%Z' "	' Z' "	" Z' "	*Z "	&Z' "	" Z' \$ "	" Z' & "
E? 6#*#\$Z% "	("	#" "	%Z' "	(Z' "	\$Z' "	#' Z' "	&Z' "	" Z' * "	" Z' % "

FZWd_ S^6 WdSfja` 5 ZScZ:Za V

Model									
	-40	-20	0	25	40	50	60	70	85
E? 6#*#\$Z" #"	" Z#("	" Z#& "	" Z#\$ "	" Z#"	" Z' "	" Z' "	" Z' ("	" Z' "	" Z' % "
E? 6#*#\$Z" #&	" Z\$" % "	" Z#+ "	" Z#)	" Z#& "	" Z#\$ "	" Z#" "	" Z' + "	" Z' "	" Z' ("
E? 6#*#\$Z" \$"	" Z\$+ "	" Z\$("	" Z\$" % "	" Z\$" "	" Z#)	" Z#'	" Z#& "	" Z#\$ "	" Z#" "
E? 6#*#\$Z" %"	" Z&& "	" Z%+ "	" Z%" "	" Z%" "	" Z\$("	" Z\$" % "	" Z\$# "	" Z#" "	" Z#'
E? 6#*#\$Z" ' "	" Z' + "	" Z') "	" Z' "	" Z' "	" Z&' "	" Z&% "	" Z%" "	" Z%" "	" Z\$" % "
E? 6#*#\$Z")'	#Z#" "	" Z'+ "	" Z') "	" Z')'	" Z(% "	" Z') "	" Z&+ "	" Z&' "	" Z%" "
E? 6#*#\$Z#"	#Z("	#Z&' "	#Z\$* "	#Z#" "	" Z'+ \$ "	" Z' % "	" Z' # "	" Z(("	" Z' \$ "
E? 6#*#\$Z#&'	\$Z' "	#Z')'	#Z' \$ "	#Z\$' "	#Z' "	" Z'+ "	" Z'+ "	" Z')'	" Z' % "
E? 6#*#\$Z#' "	\$Z%" "	\$Z' "	#Z') "	#Z' "	#Z\$" % "	#Z' + "	" Z'+ "	" Z' \$ "	" Z(# "
E? 6#*#\$Z#("	\$Z#" "	#Z+("	#Z' * "	#Z("	#Z\$("	#Z#\$ "	" Z'+ "	" Z' & "	" Z(% "
E? 6#*#\$Z\$' "	\$Z' "	\$Z(# "	\$Z\$' "	\$Z' "	#Z' "	#Z(("	#Z&' "	#Z' + "	" Z' "
E? 6#*#\$Z\$("	%Z+ "	%Z&\$ "	\$Z+("	\$Z("	\$Z&% "	\$Z' "	#Z+& "	#Z%" "	#Z' "
E? 6#*#\$Z% "	&Z#'	%Z("	%Z&("	%Z' "	\$Z' "	\$Z\$* "	\$Z' # "	#Z(# "	#Z&% "
E? 6#*#\$Z% "	&Z' & "	&Z%+ "	&Z' & "	%Z' "	\$Z'+ "	\$Z(("	\$Z%" "	#Z' * "	#Z' "

BBF5

D WeVffST WBF 5 E Ž \$" #* E WdWe

7 WUfdUS ^5 Z SdSUFWdfe fUe

E? 6 \$" #* Ž" %	("	#" "	" Ž%"	" Ž"	" Ž+	#Z	%Z	" Ž "	\$Ž%"		
E? 6 \$" #* Ž" "	("	#" "	" Ž "	#Ž"	#Z	\$Z	%Z	" Ž"	#Z "		
E? 6 \$" #* Ž#"	#! %%	#" "	#Ž"	\$Ž	#Ž		" Ž"	#Z "	!	!	\$Ž

F ZWd_ S^6 WdSfj` 5 ZSdfZ;ZaV

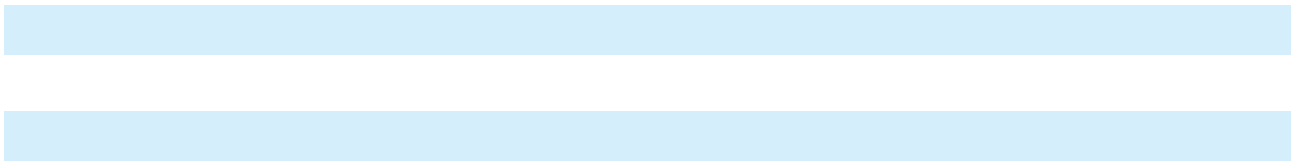

D WëWfST WBF 5 E Ž \$+\$" E VdVë

7 WUfqUS ^5 ZScSUWde flUe

Products model	Vmax (dc)	Imax (A)	Ihold @ 25 (A)	Itrip @ 25 (A)	Pd Max (W)	Max Time to trip		Resistance	
						Current (A)	Time (Sec)	Rmin (Ω)	R1max(Ω)
E ? 6 \$+\$" Ž" %	("	#"	" Ž%	" Ž "	#Ž	#Ž	%Ž	" Ž" "	&Ž" "
E ? 6 \$+\$" Ž" ' "	("	#"	" Ž "	#Ž "	#Ž	\$Ž	&Ž	" Ž#"	#Ž&" "
E ? 6 \$+\$" Ž")'	%%	&"	" Ž)'	#Ž "	#Ž	* Ž	" Ž%	" Ž#"	#Ž" "
E ? 6 \$+\$" Ž#* "	%%	&"	#Ž "	\$Ž "	#Ž	* Ž	" Ž	" Ž ('	" Ž&#" "
E ? 6 \$+\$" Ž# \$'	%%	&"	#Ž\$'	\$Ž "	#Ž	* Ž	\$Ž	" Ž" "	" Ž\$" "
E ? 6 \$+\$" Ž#* "	%%	&"	#Ž "	%Ž "	#Ž	* Ž	\$Ž	" Ž %	" Ž\$%" "
E ? 6 \$+\$" Ž#* "	%%	&"	#Ž* "	%Ž "	#Ž	* Ž	\$Ž	" Ž %	" Ž# " "
E ? 6 \$+\$" Ž\$* "	#(! \$&	&"	\$Ž "	&Ž "	#Ž	* Ž	&Ž	" Ž \$"	" Ž# \$" "
E ? 6 \$+\$" Ž\$* "	#(&"	\$Ž "	' Ž "	#Ž	* Ž	#(Ž	" Ž \$"	" Ž* "
E ? 6 \$+\$" Ž\$("	(&"	\$Ž("	' Ž\$ "	#Ž	* Ž	#" Ž	" Ž #&	" Ž)' "
E ? 6 \$+\$" Ž% "	(!#(&"	%Ž "	(Ž "	#Ž	* Ž	\$" Ž	" Ž # \$	" Ž & "

BBF5

FZWd_S^6 Wsfja` 5 ZScZ:Za V

Model									
	-40	-20	0	25	40	50	60	70	85
E ? 6 \$+\$" Ž" %	" Ž\$'	" Ž&"	" Ž%	" Ž%	" Ž\$'	" Ž\$%	" Ž\$"	" Ž#)	" Ž#&
E ? 6 \$+\$" Ž" ' "	" Ž) (" Ž(" Ž +	" Ž "	" Ž&\$	" Ž%*	" Ž%&	" Ž\$ +	" Ž\$%
E ? 6 \$+\$" Ž")'	# Ž#%	# Ž#	" Ž* "	" Ž)'	" Ž(\$	" Ž (" Ž "	" Ž&&	" Ž&&
E ? 6 \$+\$" Ž#* "	# Ž((# Ž&)	# Ž\$ +	# Ž "	" Ž+ #	" Ž" %	" Ž) %	" Ž(&	" Ž "
E ? 6 \$+\$" Ž# \$'	# Ž* +	# Ž(*	# Ž&(# Ž\$'	# Ž' &	" Ž+ &	" Ž" %	" Ž) %	" Ž (
E ? 6 \$+\$" Ž#* "	\$ Ž\$)	\$ Ž#	# Ž) (# Ž "	# Ž\$'	# Ž#%	# Ž "	" Ž)	" Ž) &
E ? 6 \$+\$" Ž#* "	\$ Ž"	\$ Ž&)	\$ Ž#)	# Ž*'	# Ž' &	# Ž% +	# Ž\$ \$	# Ž)	" Ž*'
E ? 6 \$+\$" Ž\$* "	% Ž \$	\$ Ž(*	\$ Ž&&	\$ Ž "	# Ž((# Ž "	# Ž&\$	# Ž#(" Ž+ "
E ? 6 \$+\$" Ž\$* "	% Ž) *	% Ž%&	\$ Ž+ %	\$ Ž "	\$ Ž* "	# Ž* "	# Ž('	# Ž&'	# Ž#%
E ? 6 \$+\$" Ž\$("	% Ž(&	% Ž\$'	\$ Ž+ #	\$ Ž("	\$ Ž\$(\$ Ž* "	# Ž+ '	# Ž) &	# Ž#%
E ? 6 \$+\$" Ž% "	& Ž %	& Ž \$	% Ž #	% Ž "	\$ Ž \$	\$ Ž\$(# Ž+ +	# Ž)'	# Ž&&

DWfST WBF 5 E Ž (H E WdWé

BSU] SYW6 [W e]a` e

Product model	A	B	C	D	E	H	Lead Size
	Max	Max	Max	Min	Max	Typical	
(HŽ")'	*Z	*Z%	%Z)Z('Z	#Z	V,"Z
(HŽ"+)Z&	##Z(%Z)Z('Z	#Z	V,"Z
(HŽ##")Z&	#\$Z)	%Z)Z('Z	#Z)	V,"Z
(HŽ#\$")Z&	##Z)	%Z)Z('Z	#Z	V,"Z
(HŽ#%")Z&	#\$Z)	%Z)Z('Z	#Z	V,"Z
(HŽ#(")Z(##Z(%Z)Z('Z	#ZS	V,"Z
(HŽ#**)Z+	##Z)	%Z)Z('Z	#ZS	V,"Z
(HŽS'"	+Z&	#&Z	%Z)Z('Z	#Z	V,"Z

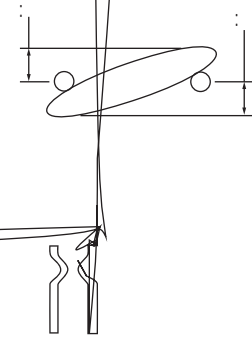

	IH	IT	IMAX	VMAX	Trip		Pdtyp	Rmin	Rmax	R1max
	(A)	(A)	(A)	(V)	(A)	(S)	(W)	(Ω)	(Ω)	(Ω)
(HŽ")')'	#Z%	&"	(Z	*Z	"Z&	"Z%	"Z##"	"Z#)'	"ZS%
(HŽ"+	"Z+"	#Z"	&"	#(Z	*Z	#ZS	"Z("Z)"	"Z#S"	"Z#"
(HŽ##"	#Z##"	SZS"	&"	(Z	*Z	SZ%	"Z)"	"Z'"	"Z+'"	"Z#&
(HŽ#\$"	#ZS"	SZ"	&"	(Z	*Z	"Z	"Z("Z)"	"Z+)"	"Z#&
(HŽ#%"	#Z%	SZ)"	&"	#(Z	*Z	"Z&	"Z#	"Z&"	"Z)&	"Z##"
(HŽ#("	#Z(%ZS"	&"	#(Z	*Z	+Z	"Z+"	"Z%"	"Z(#	"Z##"
(HŽ#**	#Z'	%Z)"	&"	#(Z	*Z	#Z	#Z"	"Z%"	"Z'#	"Z+)
(HŽS'"	SZ"	'Z"	&"	#(Z	*Z	&"Z	#ZS#	"Z\$"	"Z%("Z(

Part number	-40	-20	0	25	40	50	60	70	85
(HŽ")'	#Z'	"Z+	"Z'	"Z)	"Z("Z("Z'	"Z"	"Z&%"
(HŽ"+	#Z&"	#ZS'	#Z##"	"Z+"	"Z)	"Z(+	"Z("Z("Z"
(HŽ##"	#Z)	#Z\$	#Z%&%"	#Z##"	"Z+)	"Z+"	"Z"	"Z)%	"Z(%)
(HŽ#\$"	#Z(+	#Z\$	#Z%(#ZS"	#Z&	"Z+("Z**	"Z"	"Z*"
(HŽ#%"	\$Z#'	#Z+&	#Z)"	#Z%	#ZS"	#Z#&	#Z"	"Z+"	"Z#"
(HŽ#("	\$Z&+	\$ZS#	#Z+&	#Z(#Z&\$	#Z%#	#Z#+	#Z%"	"Z*"
(HŽ#**	\$Z)	\$Z+	\$ZS*	#Z'	#Z(%)	#Z\$	#Z%&%"	#ZS#	#Z'
(HŽS'"	%Z\$	%Z&&	%Z%"	\$Z"	\$Z#)	\$Z"	#Z#	#Z+	#Z%+



BSUJ SYW6 L W e j a ` e

Product model	A	B	C	D	E	图式
	Max	Max	Typ	Min	Max	Fig
#(HZ")'	(Z+	## Z&	' Z#) Z(%Z'	8(Y#
#(HZ" +") Z&	##%Z&	' Z#) Z(%Z'	8(Y\$
#(HZ##") Z+	##&Z&	' Z#) Z(%Z'	8(Y\$
#(HZ#\$") Z&	##\$Z#	' Z#) Z(%Z'	8(Y#
#(HZ#%"	* Z+	##%Z	' Z#) Z(%Z'	8(Y\$
#(HZ#("	* Z+	##' Z+	' Z#) Z(%Z'	8(Y\$
#(HZ#""	## Z)	##' Z)	' Z#) Z(%Z'	8(Y\$
#(HZ\$' "	## Z	##* Z&	' Z#) Z(%Z'	8(Y\$
#(HZ%'") Z#	## Z'	' Z#) Z(%Z'	8(Y#` \$
#(HZ&'"	* Z+	##\$Z*	' Z#) Z(%Z'	8(Y#` \$
#(HZ' ""	## Z&	##&Z%	' Z#) Z(%Z'	8(Y#` \$
#(HZ(""	## Z)	##) Z#	' Z#) Z(%Z'	8(Y#` \$
#(HZ) ""	## Z&	##+ Z)	' Z#) Z(%Z'	8(Y#` \$
#(HZ* ""	## \$Z)	##\$` Z+	' Z#) Z(%Z'	8(Y#` \$
#(HZ+ ""	## &Z'	##\$# Z)	' Z#) Z(%Z'	8(Y#` \$
#(HZ#""	## (Z	##\$' Z&	' Z#) Z(%Z'	8(Y#` \$
#(HZ##""	##) Z	##\$(Z'	' Z#) Z(%Z'	8(Y#` \$
#(HZ#\$""	##) Z	##\$* Z'	' Z#) Z(%Z'	8(Y#` \$
#(HZ#&""	## \$%Z	##\$) Z+	##" Z&) Z(%Z'	8(Y#` \$

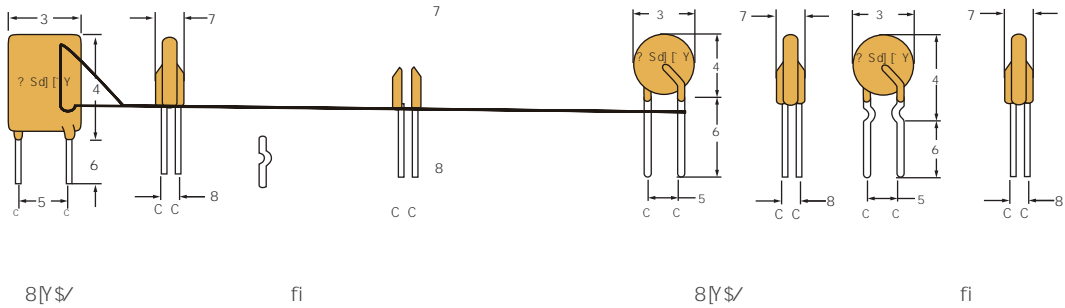

D WdWfST WBF 5 E Ž # (H E WdWd

7 WdUdUS ^5 Z SdSUFWdfeUe

Products model	IH	IT	IMAX	VMAX	Trip		Pdtyp	Rmin	Rmax	R1max
	(A)	(A)	(A)	(V)	(A)	(S)	(W)	(Ω)	(Ω)	(Ω)
#(H2*)'	" ž'	# Ž%	&"	#(%ž'	" ž&	" Ž%	" ž#&	" ŽS%	" Ž%
#(H2*+)	" ž+ "	# ž" "	&"	#(&ž "	# žS	" ž("	" ž# "	" ž# *	" žS&
#(H2##)	# ž# "	\$ žS "	&"	#(' ž "	\$ ž%	" ž "	" ž * "	" ž#&	" žS#
#(H2#\$)	# ž\$ "	\$ ž" "	&"	#((ž "	" ž "	" ž("	" ž * "	" ž#&	" žS#
#(H2#%)	# ž% "	\$ ž) "	&"	#((ž)'	&ž "	" ž # "	" ž ("	" ž# \$ "	" ž# + "
#(H2#('	# ž("	%žS "	&"	#(* ž" "	+ žS "	" ž+ "	" ž' "	" ž# # "	" ž# *
#(H2#*')	# ž*'	%ž) "	&"	#(+ žS'	# ž" "	# ž" "	" ž' "	" ž + "	" ž#&
#(H2\$')	\$ ž" "	' ž" "	&"	#(# \$ž "	# ž" "	# žS# "	" ž % "	" ž ("	" ž# \$ "
#(H2%')	%ž'	' ž# "	#" "	#(# ž" "	\$ ž" "	\$ ž%	" ž % "	" ž) "	" ž + "
#(H2&')	&ž'	(ž" "	#" "	#(\$ ž" "	%ž "	\$ ž&	" ž \$# "	" ž & "	" ž ("
#(H2')'	' ž' "	* ž" "	#" "	#(\$ ž" "	%ž("	\$ ž("	" ž #' "	" ž \$' "	" ž %S "
#(H2()'	(ž' "	# žS "	#" "	#(% ž" "	' ž" "	\$ ž" "	" ž # "	" ž \$ "	" ž S("
#(H2))') ž' "	## ž+ "	#" "	#(% ž" "	* ž" "	%ž'	" ž * "	" ž #' "	" ž S' "
#(H2*)'	* ž' "	## ž("	#" "	#(& ž" "	+ ž" "	%ž'	" ž ("	" ž # \$ "	" ž # ("
#(H2+)'	+ ž' "	# ž' "	#" "	#(& ž" "	# \$ž "	%ž%	" ž ' "	" ž # # "	" ž # & "
#(H2#)'	# ž' "	#) ž' "	#" "	#(' ž" "	# \$ž "	%ž("	" ž ' & "	" ž * + "	" ž # # "
#(H2##)'	## ž' "	#* ž) "	#" "	#(' ž" "	# %ž "	%ž)	" ž ' & "	" ž * "	" ž # "
#(H2#\$)'	# \$ž' "	\$ ž ž&	#" "	#((ž" "	# (ž" "	&žS "	" ž ' & "	" ž) "	" ž + "
#(H2#&)'	# &ž' "	\$ %ž'	#" "	#() ž" "	\$ ž" "	&ž("	" ž % "	" ž ' "	" ž) "

F ZWd_ S^6 WdSfā 5 Z Sdž:Za V

Part number	-40	-20	0	25	40	50	60	70	85
#(H2*)'	# ž' "	" ž+ "	" ž' "	" ž)'	" ž('	" ž("	" ž' "	" ž" "	" žS%
#(H2*+)	# ž&" "	# žS "	# ž# "	" ž+ "	" ž)'	" ž(+ "	" ž('	" ž("	" ž" "
#(H2##)	# ž)'	# ž \$ "	# ž% "	# ž# "	" ž+ + "	" ž+ "	" ž" "	" ž) "	" ž(% "
#(H2#\$)	# ž(+ "	# ž \$ "	# ž% ("	# žS "	# ž & "	" ž+ ("	" ž * "	" ž * "	" ž(* "
#(H2#%)	\$ ž# "	# ž+ & "	# ž) "	# ž% "	# žS "	# ž# & "	# ž" "	" ž+ "	" ž # "
#(H2#('	\$ ž&+ "	\$ žS# "	# ž+ & "	# ž("	# ž& \$ "	# ž%# "	# ž# + "	# ž % "	" ž * "
#(H2#*')	\$ ž("	\$ ž + "	\$ žS * "	# ž' "	# ž(% "	# ž \$ "	# ž% % "	# žS# "	# ž' "
#(H2\$')	%ž \$ "	%ž&& "	%ž % "	\$ ž" "	\$ ž# "	\$ ž" "	# ž # "	# ž + "	# ž% + "
#(H2%')	&ž&" "	&ž" "	%ž("	%ž" "	\$ ž("	\$ ž&" "	\$ ž# "	# ž+ "	# ž&" "
#(H2&')	' ž+ "	' ž% "	&ž" "	%ž" "	%ž" "	%žS "	\$ ž" "	\$ ž" "	# ž+ "
#(H2')') ž% "	(ž("	(ž" "	' ž" "	&ž&" "	&ž" "	%ž("	%ž# "	\$ ž&" "
#(H2()'	* ž" "	* ž" ") žS "	(ž" "	' žS "	&ž" "	&žS "	%ž" "	\$ ž" "
#(H2))'	# ž% "	+ ž% "	* ž&" ") ž" "	(žS "	' ž("	' ž" "	&ž&" "	%ž% "
#(H2*)'	## ž) "	# ž) "	+ ž("	* ž" "	(ž&" "	' ž("	' ž# "	' ž# "	%ž) "
#(H2+)'	# %žS "	# # ž+ "	# # ž) "	+ ž" ") ž+ ") žS "	(ž&" "	' ž("	&žS "
#(H2#)'	# &ž) "	# %ž% "	# \$ž "	# ž" "	* ž) "	* ž" ") ž" "	(ž% "	&ž) "
#(H2##)'	# (ž# "	# &ž("	# %ž# "	## ž' "	+ ž) "	* ž" ") ž" "	(ž+ "	' žS "
#(H2#\$)'	#) ž("	# (ž' "	# &ž&" "	# \$ž' "	# ž&" "	+ ž("	* ž&" ") ž("	' ž("
#(H2#&)'	\$ ž" "	# * ž) "	# (ž' "	# &ž' "	# \$ž# "	# # žS "	+ ž" "	* ž+ "	(ž" "

D VêWfST WBF 5 E Ž %" H E WdWê

BSUJ SYW6 [W e[a` e

% HZ* &") z+	#%Q	' 2#) Ž(%Z	" Ž(" Z' 5
% HZ* ' ") Ž&	# \$ZS	' 2#) Ž(%Z	" Ž(" Z' 5
% HZ*)') Ž&	# \$ZS	' 2#) Ž(%Z	" Ž(" Z' 5
% HZ* +") Ž&	# \$ZS	' 2#) Ž(%Z	" Ž(" Z'
% HZ##") Ž&	# &ZS	' 2#) Ž(%Z	" Ž(" Z'
% HZ#%"	* z+	#%Z	' 2#) Ž(%Z	" Ž(" Z'
% HZ#("	* z+	#' ZS	' 2#) Ž(%Z	" Ž(" Z'
% HZ#*"	#" ZS	#' Ž)	' 2#) Ž(%Z	" Ž(" Z'
% HZ\$""	#" ZS	#' ZS	' 2#) Ž(%Z	" Ž(" Z'
% HZ\$' "	## Ž&	#* Ž%	' 2#) Ž(%Z	" Ž(" Z'
% HZ%""	## Ž&	#) Ž%	' 2#) Ž(%Z	" Ž(" Z'
% HZ&""	# &Z'	S" 2#	' 2#) Ž(%Z	" Ž(" Z'
% HZ' ""	# &Z'	S&Z+	#" ZS) Ž(%Z	" Ž(" Z'
% HZ(" "	#* Z'	S&Z+	#" ZS) Ž(%Z	" Ž(" Z'
% HZ) ""	#+ 2#	S(Ž)	#" ZS) Ž(%Z	" Ž(" Z'
% HZ* ""	\$# Ž(S+ ZS	#" ZS) Ž(%Z	" Ž(" Z'
% HZ+ ""	\$&Z#	S+ Ž)	#" ZS) Ž(%Z	" Ž(" Z'

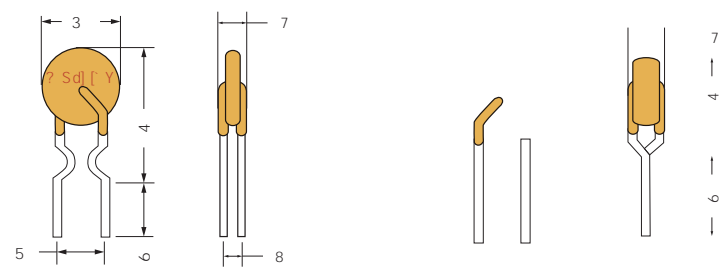

D WdWfST WBF 5 E Ž %" H E WdWd

7 WdUfUS ^5 Z SdSUFWdfe[Ue

Products model	IH	IT	IMAX	VMAX	Trip		Pdtyp	Rmin	Rmax
	(A)	(A)	(A)	(V)	(A)	(S)	(W)	(Ω)	(Ω)
% HZ * & "	" Z&"	" Z "	&"	%	\$Z "	' Z "	" Z(" Z&"	#Z D#
% HZ " ' "	" Z "	#Z "	&"	%	\$Z "	&Z "	" Z(" Z&+"	" Z #"
% HZ ") ' "	" Z) "	#Z "	&"	%	%Z "	' Z&	" Z(" Z#&"	" Z& "
% HZ " + "	" Z+ "	#Z "	&"	%	&Z "	' Z+	" Z(" Z) "	" Z# \$"
% HZ # # "	#Z# "	\$Z&"	&"	%	' Z * "	(Z(" Z) "	" Z' "	" Z# "
% HZ # % "	#Z% "	\$Z) "	&"	%	(Z) ") Z%	" Z "	" Z &"	" Z * "
% HZ # (" "	#Z(" "	%Z&"	&"	%	* Z " "	* Z "	" Z+ "	" Z %"	" Z) "
% HZ # * ' "	#Z* ' "	%Z) "	&"	%	+Z&' "	* Z) "	#Z "	" Z %"	" Z ("
% HZ \$ " "	\$Z " "	&Z " "	&"	%	# " Z "	+Z "	#Z&	" Z &"	" Z # "
% HZ \$ " "	\$Z " "	' Z " "	&"	%	# \$Z " "	# " Z%	#Z&	" Z \$ "	" Z & "
% HZ % " "	%Z " "	(Z " "	&"	%	# ' Z " "	# " Z "	\$Z "	" Z \$ "	" Z ' "
% HZ & " "	&Z " "	* Z " "	&"	%	\$ " Z " "	# \$Z) "	\$Z "	" Z # "	" Z % "
% HZ ' " "	' Z " "	# " Z " "	&"	%	\$ " Z " "	# &Z "	%Z "	" Z # "	" Z % "
% HZ (" "	(Z " "	# \$Z " "	&"	%	% Z " "	# (Z "	%Z "	" Z' "	" Z \$ "
% HZ) " ") Z " "	# &Z " "	&"	%	% Z " "	#) Z "	%Z "	" Z' "	" Z \$ "
% HZ * " "	* Z " "	# (Z " "	&"	%	& " Z " "	# * Z "	&Z "	" Z' "	" Z \$ "
% HZ + " "	+Z " "	# * Z " "	&"	%	& " Z " "	\$ " Z "	&Z&	" Z' "	" Z # "

F ZWd_ S^6 WdSfj^ 5 Z SdZ; Za V

Part number	-40	-20	0	25	40	50	60	70	85
% HZ * & "	" Z(" Z +	" Z "	" Z&"	" Z%&	" Z%&	" Z&(" Z&"	" Z#&
% HZ " ' "	" Z %"	" Z) &	" Z(%"	" Z "	" Z&#"	" Z%&	" Z%&	" Z&"	" Z# "
% HZ ") ' "	#Z&(#Z#&#	" Z+ "	" Z) ' "	" Z(#"	" Z & "	" Z& "	" Z%&+	" Z& "
% HZ " + "	#Z&"	#Z&"	#Z# "	" Z+ "	" Z) ' "	" Z(+ "	" Z(' "	" Z("	" Z " "
% HZ # # "	#Z) ' "	#Z \$ "	#Z%&	#Z# "	" Z+ + "	" Z+ "	" Z " "	" Z) %"	" Z(%"
% HZ # % "	\$Z# ' "	#Z+&	#Z) "	#Z%&	#Z&"	#Z#&	#Z " "	" Z+ "	" Z # "
% HZ # (" "	\$Z&+ "	\$Z&# "	#Z+&	#Z(" "	#Z&\$ "	#Z%# "	#Z# + "	#Z %"	" Z * "
% HZ # * ' "	\$Z* " "	\$Z + "	\$Z&\$ "	#Z* " "	#Z(%"	#Z \$ "	#Z%&	#Z&# "	#Z' "
% HZ \$ " "	%Z(\$ "	\$Z) "	\$Z&\$ "	\$Z " "	#Z) &	\$Z(" "	#Z& "	#Z&"	#Z# \$"
% HZ \$ " "	%Z* \$ "	%Z&&	%Z % "	\$Z " "	\$Z " "	\$Z# "	#Z # "	#Z + "	#Z%&+
% HZ % " "	&Z ' "	&Z# "	%Z(" "	%Z " "	\$Z(' "	\$Z # "	\$Z&&	\$Z # "	#Z) &
% HZ & " "	(Z " "	' Z&"	&Z) &	&Z " "	%Z&	%Z& "	\$Z \$ "	\$Z(%"	\$Z&(
% HZ ' " ") Z&&	(Z * "	' Z " "	' Z " "	&Z%&	&Z \$ "	%Z * "	%Z&\$ "	\$Z) "
% HZ (" "	" Z+ ") Z+ + ") Z * "	(Z " "	' Z#%&	&Z \$ "	&Z&	%Z &	%Z%&
% HZ) " "	# " Z%&	+Z%&	* Z&# ") Z " "	' Z+ "	' Z * "	&Z+ (&Z&(%Z &
% HZ * " "	#Z(" "	# " Z(" "	+Z%&	* Z " "	(Z) + "	(Z%&	' Z &	' Z) "	&Z%&
% HZ + " "	#Z&' "	#Z+ "	# " Z&+ "	+Z " ") Z % ") Z# \$"	(Z%&	' Z(+ "	&Z* "

D VēwfST WBF 5 E Ž (" H E WdVē

Product model	A	B	C	D	E	Lead ø	
	Max	Max	Max	Min	Max	Unit:mm	
(" HŽ" "") Ž&	# \$Ž	' Ž#) Ž	%#	6;	" Ž
(" HŽ" #") Ž&	## Ž	' Ž#) Ž	%#	6;	" Ž
(" HŽ" #)) Ž&	# \$Ž	' Ž#) Ž	%#	6;	" Ž
(" HŽ" \$") Ž&	## Ž	' Ž#) Ž	%#	6;	" Ž
(" HŽ" \$') Ž&	# \$Ž	' Ž#) Ž	%#	6;	" Ž
(" HŽ" %") Ž&	# \$Ž	' Ž#) Ž	%#	6;	" Ž
(" HŽ" &") Ž	% Ž	' Ž#) Ž	%#	6;	" Ž
(" HŽ" ' ") Ž+	% Ž	' Ž#) Ž	%#	6;	" Ž
(" HŽ" ('	+ Ž&	# & Ž	' Ž#) Ž	%#	6;	" Ž
(" HŽ")'	#" Ž&	#' Ž&	' Ž#) Ž	%#	6;	" Ž
(" HŽ" +"	## Ž&	#' Ž	' Ž#) Ž	%#	6;	" Ž
(" HŽ##"	# \$Ž'	#) Ž	' Ž#) Ž	%#	6L	" Ž
(" HŽ#%"	# & Ž	# + Ž#	' Ž#) Ž	%#	6L	" Ž
(" HŽ#("	# (Ž%	\$" Ž	' Ž#) Ž	%#	6L	" Ž
(" HŽ#" "	#) Ž	\$\$ Ž&	' Ž#) Ž	%#	6L	" Ž
(" HŽ\$' "	\$" Ž'	\$' Ž&	#" Ž&) Ž	%#	6L	" Ž
(" HŽ%'"	\$% Ž+	\$* Ž	#" Ž&) Ž	%#	6L	" Ž
(" HŽ%)'	\$) Ž&	%# Ž'	#" Ž&) Ž	%#	6L	" Ž
(" HŽ' ""	\$) Ž&	%# Ž'	#" Ž&) Ž	%#	6L	" Ž

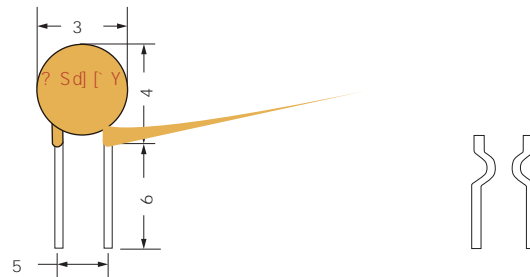

D WdWfST WBF 5 E Ž (" H E WdWd

7 WwfdUS ^5 Z SdSUFWdfeUe

(" HZ" ""	" Z "	" Z#"	" &"	("	" ZS'	' Z'	" Z%") Z "	# \$Z'	#' Z'
(" HZ" #"	" Z#"	" ZS"	" &"	("	" Z "	* Z'	" Z #	\$Z "	&Z "	(Z'
(" HZ" #)	" Z#"	" Z&&"	" &"	("	" Z' "	' Z'	" Z'"	\$Z "	%ZS"	&Z
(" HZ" \$"	" ZS"	" Z&"	" &"	("	" #Z"	%Z(" Z \$	#Z "	\$Z' &	%Z'
(" HZ" \$'	" ZS'	" Z "	" &"	("	" #ZS'	%ZS	" Z \$	#Z "	#Z+ "	\$Z'
(" HZ" %"	" Z%"	" Z'"	" &"	("	" #Z "	%Z'	" Z +	" Z) (#Z("	" HZ" %"

F ZWd_ S^6 WdSfj^ 5 ZSdZ;Za V

Part number	-40	-20	0	25	40	50	60	70	85
(" HZ" ""	" Z))	" Z (+	" Z (#	" Z' "	" Z &&"	" Z &"	" Z %(" Z %\$	" Z \$'
(" HZ" #"	" Z#"*	" Z#"'	" Z#"%	" Z#" "	" Z' *	" Z' "	" Z' (" Z' "	" Z' %
(" HZ" #)	" ZS*	" ZS&"	" ZS"	" Z#" "	" Z# &"	" Z#\$	" Z#" "	" Z' +	" Z' (
(" HZ" \$"	" Z&&"	" ZS+	" ZS'	" ZS"	" Z# (" Z# &"	" Z#" %	" Z#" "	" Z')
(" HZ" \$'	" Z&\$	" Z%(" Z%#	" ZS'	" ZS"	" Z#"*	" Z# (" Z#\$	" Z' +
(" HZ" %"	" Z \$	" Z&&"	" Z%"	" Z%"	" ZS&"	" ZS\$	" Z#"*	" Z# &"	" Z#" "
(" HZ" &"	" Z((" Z)	" Z "	" Z&"	" Z%\$	" ZS+	" ZS&"	" ZS"	" Z# &"
(" HZ" ' "	" Z'"	" Z) &"	" Z(%	" Z "	" Z&#	" Z%(" Z%"	" ZS"	" Z#" "
(" HZ" (" Z#" "	" Z+ "	" Z' \$	" Z('	" Z' %	" Z&"	" Z&"	" Z%&"	" ZS&"
(" HZ")'	#ZS(#Z# #	" Z+ "	" Z('	" Z(#	" Z &"	" Z&'	" Z%+	" ZS*
(" HZ" +"	#Z \$	#Z%"	#Z#'	" Z+ "	" Z) %	" Z('	" Z' "	" Z&)	" Z%&"
(" HZ" #"	#Z' \$	#Z("	#Z%&"	#Z#" "	" Z' +	" Z) +	" Z('	" Z' "	" Z&"
(" HZ" #%)	\$ZS"	#Z+ #	#Z('	#Z%&"	#Z' +	" Z+ (" Z'"	" Z(*	" Z "
(" HZ" #)	\$Z("	\$Z%&"	#Z+'	#Z("	#Z%&"	#Z# %	#Z' "	" Z'"	" Z("
(" HZ" #"	%Z' "	\$Z(%	\$Z%&"	#Z' "	#Z' "	#Z%&"	#Z# \$	" Z+ \$	" Z()
(" HZ" \$"	&Z' "	%Z' *	%Z' \$	\$Z "	\$Z' \$	#Z' "	#Z' "	#Z%&"	" Z+ "
(" HZ" \$"	&Z' \$	&Z# (%Z(\$	%Z' "	\$Z&%&"	\$Z# (#Z' "	#Z' "	#Z' +
(" HZ" %)	(Z' \$	' Z# +	&Z' "	%Z('	%Z' \$	\$Z(*	\$Z%&"	#Z+'	#Z%+
(" HZ' "") Z&&"	(Z(*	' Z' "	' Z' "	&Z%&"	&Z' %	%Z' *	%ZS\$	\$Z))



D VêWfST WBF 5 E Z) \$H E WdWê

BSUJ SYW6 [W e[a` e

Product model	A	B	C	D	E	Lead ø	
	Max	Max	Max	Min	Max	Unit:mm	
) \$HŽ" "") Ž&	# \$Z)	' Ž#) Ž(%Ž#	6;	" Z
) \$HŽ" #") Ž&	## Ž(' Ž#) Ž(%Ž#	6;	" Z
) \$HŽ" #)) Ž&	# \$Z)	' Ž#) Ž(%Ž#	6;	" Z
) \$HŽ" \$") Ž&	## Ž)	' Ž#) Ž(%Ž#	6;	" Z
) \$HŽ" \$') Ž&	# \$Z)	' Ž#) Ž(%Ž#	6;	" Z
) \$HŽ" %&) Ž&	# \$Z)	' Ž#) Ž(%Ž#	6;	" Z
) \$HŽ" &") Ž(## ŽZ	' Ž#) Ž(%Ž#	6;	" Z
) \$HŽ" "") Ž+	## ŽZ)	' Ž#) Ž(%Ž#	6;	" Z
) \$HŽ" ('	+ Ž&	# &Z	' Ž#) Ž(%Ž#	6;	" Ž(
) \$HŽ")'	#" Ž&	#' Ž&	' Ž#) Ž(%Ž#	6;	" Ž(
) \$HŽ" +"	## Ž&	#' Ž"	' Ž#) Ž(%Ž#	6;	" Ž(
) \$HŽ" ##"	# \$Z"	#) Ž	' Ž#) Ž(%Ž#	6L	" Ž"
) \$HŽ" #%	# &Z	# + Ž#	' Ž#) Ž(%Ž#	6L	" Ž"
) \$HŽ" #('	# (Ž%	\$" Ž"	' Ž#) Ž(%Ž#	6L	" Ž"
) \$HŽ" #"'	#) Ž	\$\$ Ž&	' Ž#) Ž(%Ž#	6L	" Ž"
) \$HŽ" \$" "	\$" Ž"	\$' Ž&	#" Ž&) Ž(%Ž#	6L	" Ž"
) \$HŽ" %&"	\$%Ž+	\$* Ž(#" Ž&) Ž(%Ž#	6L	" Ž"
) \$HŽ" %&'	\$) Ž&	%# Ž"	#" Ž&) Ž(%Ž#	6L	" Ž"
) \$HŽ" ""	\$) Ž&	%# Ž"	#" Ž&) Ž(%Ž#	6L	" Ž"

BBF5

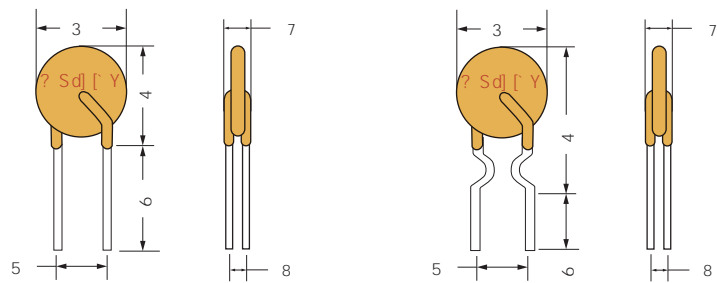

D WdWfST WBF 5 E Ž) \$H E WdWd

7 WdUdUS ^5 ZsdUfWd[f]Ue

Products model	IH	IT	IMAX	VMAX	Trip		Pdtyp	Rmin	Rmax	R1max
	(A)	(A)	(A)	(V)	(A)	(S)	(W)	(Ω)	(Ω)	(Ω)
) SHZ*''	" Z '	" #"	&"	("	" ZS'	' Z'	" Z%") Z "	# \$Z'	#' Z'
) SHZ* #"	" #"	" ZS"	&"	("	" Z "	* Z'	" Z #"	\$Z "	&Z "	(Z'
) SHZ* #)	" #)"	" Z&"	&"	("	" Z*'	' Z'	" Z(\$Z "	%ZS"	&Z'
) SHZ* \$"	" ZS"	" Z&"	&"	("	" #Z"	%Z(" Z \$"	#Z "	\$Z' &	%Z'
) SHZ* \$'	" ZS'	" Z "	&"	("	" #ZS'	%ZS	" Z \$"	#Z "	#Z+ "	\$Z'
) SHZ* %"	" Z%"	" Z(&"	("	" #Z "	%Z'	" Z +"	" Z(# Z%(# Z "
) SHZ* &"	" Z&"	" Z"	&"	("	" \$Z "	%Z*	" Z(" Z \$"	" Z(# #"
) SHZ* ' "	" Z "	" #Z "	&"	("	" \$Z "	&Z'	" Z "	" Z&#"	" Z)	# Z "
) SHZ* ('	" Z ('	" #Z%"	&"	("	" %ZS'	' Z%	" Z+ "	" ZS)	" Z&*	" Z(
) SHZ*)'	" Z)'	" #Z "	&"	("	" %Z)	(Z%)	" Z+ "	" #Z*"	" Z& "	" Z "
) SHZ* +"	" Z+ "	" #Z "	&"	("	" &Z') ZS)	" Z "	" #Z &	" Z%#"	" Z&\$"
) SHZ* #"	# Z"	\$ ZS"	&"	("	' Z'	* ZS'	# Z #"	" #Z &	" ZS'	" Z%%"
) SHZ* #)	# Z%)"	\$ Z)"	&"	("	(Z)'	+ Z(# Z) #"	" #Z \$"	" #Z+ "	" ZS(
) SHZ* #)	# Z(%ZS"	&"	("	* Z'	# #Z&	# Z+*"	" Z +"	" #Z &	" #Z+ "
) SHZ* #"	# Z*"	%Z)	&"	("	+ ZS'	# \$Z'	\$ Z#"	" Z* "	" #Z \$"	" #Z(
) SHZ* \$"	\$ Z "	' Z "	&"	("	# \$Z'	#' Z'	\$ Z "	" Z' "	" Z* "	" #Z#"
) SHZ* %"	%Z "	(Z "	&"	("	#' Z "	# +Z'	\$ Z "	" Z &	" Z(" Z* "
) SHZ* %)	%Z)') Z "	&"	("	#* Z)'	\$ &Z'	%ZS"	" Z %"	" Z' "	" Z)'
) SHZ* ' "	' Z "	# " Z'	&"	("	\$' Z "	% Z'	&ZS"	" Z \$"	" Z)'	" #Z"

F ZWd_ S^6 WdSfj^ 5 ZsdZ:Za V

Part number	-40	-20	0	25	40	50	60	70	85
) SHZ*''	" Z)"	" Z (+"	" Z (#"	" Z ' "	" Z &&"	" Z &"	" Z %("	" Z %\$"	" Z \$'
) SHZ* #"	" #"	" #"	" #%"	" #"	" Z* "	" Z' "	" Z (" Z' "	" Z %"
) SHZ* #)	" ZS*"	" ZS&"	" ZS"	" #"	" #Z &"	" #Z \$"	" #Z "	" Z +"	" Z (
) SHZ* \$"	" Z%&"	" ZS+ "	" ZS'	" ZS"	" #Z(" #Z &"	" #Z%"	" #Z "	" Z)'
) SHZ* \$'	" Z&\$"	" Z%(" Z%#"	" ZS'	" ZS"	" #Z*"	" #Z(" #Z \$"	" Z +"
) SHZ* %"	" Z \$"	" Z&&"	" Z%*	" Z%"	" ZS &"	" ZS \$"	" #Z*"	" #Z &"	" #Z "
) SHZ* &"	" Z((" Z)"	" Z "	" Z&"	" Z%#"	" ZS+ "	" ZS &"	" ZS"	" #Z &"
) SHZ* ' "	" Z% "	" Z) &"	" Z(%"	" Z "	" Z&#"	" Z%(" Z%"	" ZS'	" #Z "
) SHZ* ('	" #Z"	" Z+ "	" Z* \$"	" Z(' "	" Z %"	" Z&"	" Z& "	" Z%%"	" ZS &"
) SHZ*)'	# ZS(# Z#"	" Z+ "	" Z)'	" Z(#"	" Z &"	" Z&'	" Z%+ "	" ZS*"
) SHZ* +"	# Z \$"	# Z%"	# Z'	" Z+ "	" Z) %"	" Z(' "	" Z' "	" Z& "	" Z%%"
) SHZ* #"	# Z* \$"	# Z("	# Z%"	# Z#"	" Z+ "	" Z) +"	" Z(' "	" Z' "	" Z& "
) SHZ* #)	\$ ZS"	# Z+ #"	# Z(' "	# Z%"	# Z' +"	" Z+ (" Z "	" Z(*"	" Z "
) SHZ* #)	\$ Z(\$ Z%"	# Z+ "	# Z(' "	# Z%"	# Z#"	# Z' "	" Z* "	" Z(' "
) SHZ* #"	%Z "	\$ Z(%"	# Z%"	# Z' "	" Z "	# Z%%"	# Z# \$"	" Z+ \$"	" Z()"
) SHZ* \$"	&Z'	%Z* "	%Z' \$"	\$ Z "	\$ Z' \$"	# Z "	# Z' "	# Z%"	" Z+ "
) SHZ* %"	&Z' \$"	&Z#(%Z(\$"	%Z "	\$ Z&%"	\$ Z#(# Z' "	# Z "	# Z+ "
) SHZ* %)	(Z \$"	' Z# +"	&Z "	%Z)'	%Z' \$"	\$ Z(*"	\$ Z%'"	# Z+ "	# Z%+ "
) SHZ* ' ") Z&&"	(Z(*"	' Z "	' Z "	&Z%"	&Z' %"	%Z* "	%Z\$ \$"	\$ Z))"

D WeWfST WBF 5 E Ž Š " H E WdWē

7 WufdUS ^5 Z SdSUFWefUe

Products model	IH	IT	IMAX	VMAX	Trip		Pdtyp	Rmin	Rmax	R1max
	(A)	(A)	(A)	(V)	(A)	(S)	(W)	(Ω)	(Ω)	(Ω)
S' " HZ" &	" Z &	" Z +	%Z	\$' "	#Z "	" Z&	#Z	\$%Z	(" Z ")' Z
S' " HZ" ' "	" Z ' "	" Z#"	%Z	\$' "	#Z "	" Z&"	#Z	\$Z\$Z	(" Z ") \$Z
S' " HZ" ("	" Z ("	" Z# \$"	%Z	\$' "	#Z "	" Z "	#Z	\$Z\$Z	%\$Z	&" Z
S' " HZ" * "	" Z * "	" Z# ("	%Z	\$' "	" Z%	%Z "	#Z	#&Z	\$Z\$Z	\$* Z
S' " HZ" + "	" Z + "	" Z# * "	%Z	\$' "	#Z "	%Z "	#Z	#" Z	\$" Z	\$ (Z
S' " HZ" ##	" Z# #	" Z\$ "	%Z	\$' "	#Z "	" Z' "	#Z) Z "	# # Z	# (Z
S' " HZ" # \$"	" Z# \$"	" Z\$ &	%Z	\$' "	#Z "	" Z' "	#Z	* Z "	# \$ Z	#' Z
S' " HZ" # &'	" Z# &'	" Z\$ + "	%Z	\$' "	" Z) \$'	\$Z	#Z	%Z	(Z	#" Z
S' " HZ" # * "	" Z# * "	" Z "	%Z	\$' "	#Z "	#' Z	#Z	" Z "	\$Z	#" Z
S' " HZ" \$ "	" Z\$ "	" Z& "	%Z	\$' "	#Z "	#' Z	#Z	# Z "	%Z	&Z "
S' " HZ" % "	" Z% "	" Z("	%Z	\$' "	#Z "	#' Z	#Z	# Z "	\$Z	%Z\$ "
S' " HZ" & "	" Z& "	" Z "	#" Z	\$' "	\$Z "	#' Z	\$Z	" Z' "	" Z+	\$Z "
S' " HZ" ' "	" Z' "	#Z "	#" Z	\$' "	\$Z Z	#' Z	%Z	" Z("	" Z) "	#Z% "
S' " HZ" ("	" Z("	#Z\$ "	#" Z	\$' "	%Z	#' Z	%Z	" Z "	" Z) "	#Z "
S' " HZ" * "	" Z* "	#Z("	#" Z	\$' "	&Z	* Z "	%Z	" Z& "	" Z("	#Z "
S' " HZ" # " "	#Z "	\$Z "	#" Z	\$' "	' Z	#" Z "	' Z	" Z\$ "	" Z& "	" Z) "
S' " HZ" # \$ "	#Z\$ "	\$Z& "	#" Z	\$' "	(Z	#" Z "	' Z	" Z\$ "	" Z% "	" Z "
S' " HZ" # & "	#Z& "	\$Z "	#" Z	\$' ") Z	# \$Z "	' Z	" Z# "	" Z\$ "	" Z "
S' " HZ" # ' "	#Z' "	%Z "	#" Z	\$' "	* Z	#%Z "	' Z	" Z# "	" Z\$ "	" Z "
S' " HZ" \$ "	\$Z "	&Z "	#" Z	\$' "	#' Z	#&Z "	' Z	" Z# \$"	" Z# + "	" Z% "

FZ Wd_ S^6 WdSfja ` 5 Z SdZ: Za V

Part number	-40	-20	0	25	40	50	60	70	85
S' " HZ" &	" Z) *	" Z ("	" Z ' "	" Z &	" Z %&	" Z \$ *	" Z \$ \$	" Z # *	" Z # (
S' " HZ" ' "	" Z * "	" Z) "	" Z ("	" Z ' "	" Z & "	" Z % (" Z % "	" Z \$)	" Z \$ "
S' " HZ" ("	" Z# "	" Z + "	" Z) "	" Z ("	" Z ' "	" Z "	" Z & "	" Z & "	" Z % "
S' " HZ" * "	" Z# \$ &	" Z# # "	" Z + "	" Z * "	" Z ((" Z' + "	" Z' # "	" Z & &	" Z % %
S' " HZ" + "	" Z# & "	" Z# % "	" Z# # "	" Z + "	" Z * "	" Z) "	" Z ("	" Z ' "	" Z & "
S' " HZ" ##	" Z#) #	" Z# ' #	" Z# % #	" Z# # "	" Z + #	" Z * #	" Z) #	" Z (#	" Z & (
S' " HZ" # \$"	" Z# + #	" Z#) "	" Z# & "	" Z# \$ "	" Z# & "	" Z + %	" Z * \$ "	" Z) #	" Z ' "
S' " HZ" # &'	" Z\$ \$'	" Z# + +	" Z#) \$	" Z# &'	" Z# # +	" Z# ("	" Z + %	" Z * "	" Z ("
S' " HZ" # * "	" Z\$ (+	" Z\$ & "	" Z\$ # "	" Z# "	" Z# % "	" Z# % "	" Z# \$ %	" Z# + "	" Z *)
S' " HZ" \$ "	" Z\$ \$ "	" Z\$ * "	" Z\$ ' "	" Z\$ "	" Z# "	" Z# ("	" Z# & "	" Z# \$ "	" Z + "
S' " HZ" % "	" Z&) *	" Z& \$ "	" Z&) "	" Z% "	" Z\$ ' "	" Z\$ %\$	" Z\$ & "	" Z#)	" Z# %)
S' " HZ" & "	" Z(& "	" Z) "	" Z& + "	" Z& "	" Z\$ % "	" Z# # "	" Z\$ & "	" Z# & "	" Z * "
S' " HZ" ' "	" Z' "	" Z) + "	" Z(* "	" Z' "	" Z& \$ "	" Z&) "	" Z% \$ "	" Z\$ ("	" Z\$ \$ "
S' " HZ" ("	" Z+ ("	" Z' ' "	" Z) & "	" Z("	" Z \$ "	" Z&) "	" Z& # "	" Z& ("	" Z\$ * "
S' " HZ" * "	#Z\$ "	#Z# % "	" Z+ + "	" Z * "	" Z(+ "	" Z(\$ "	" Z' "	" Z&)	" Z&) "
S' " HZ" # " "	#Z + "	#Z\$ \$ "	#Z\$ % "	#Z "	" Z) "	" Z) * "	" Z(* "	" Z + "	" Z& ("
S' " HZ" # \$ "	#Z+ #	#Z& "	#Z& * "	#Z\$ "	#Z & "	" Z+ % "	" Z \$ "	" Z) # "	" Z' "
S' " HZ" # & "	\$Z\$ % "	#Z+ * "	#Z) % "	#Z& "	#Z\$ # "	#Z + "	" Z+ ("	" Z % "	" Z(& "
S' " HZ" # ' "	\$Z% + "	\$Z# % "	#Z' ' "	#Z' "	#Z% "	#Z# ("	#Z % "	" Z + "	" Z(+ "
S' " HZ" \$ "	%Z# * "	\$Z' % "	\$Z&) "	\$Z' "	#Z) % "	#Z' "	#Z&) "	#Z# * "	" Z+ \$ "

D WëWfST WBF 5 E Ž (" " H E WdVë

BSU] SYW6 [W eja` e

Product model	A	B	C	D	Lead Size
	Max	Max	Max	Min	
(" " HZ" %")	#%Z	#Sž	(Z	&ž	" ž
(" " HZ" &")	#%Z	#Sž	(Z	&ž	" ž
(" " HZ" (")	#%Z	#Sž	(Z	&ž	" ž
(" " HZ" "")	#%Z	#Sž	(Z	&ž	" ž
(" " HZ"##")	#%Z	#Sž	(Z	&ž	" ž
(" " HZ"#")	#%Z	#Sž	(Z	&ž	" ž
(" " HZ#" (")	#&Z	#&Z	(ž	' ž#	" ž
(" " HZ\$" "")	#&Z	#&Z	(ž	' ž#	" ž

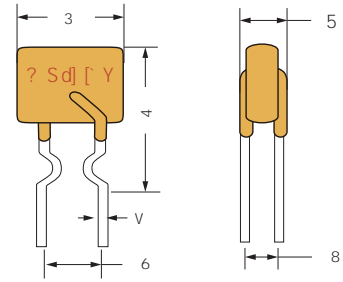

7 WdfqUS ^5 ZScSUWdfUe

Products model	IH	IT	IMAX	VMAX	Trip		Rmin	Rmax	Lead
	(A)	(A)	(A)	(V)	(A)	(S)	(Ω)	(Ω)	(Φmm)
(" " HZ" %")	" Z %	" Z (%Z	(" "	#Z	\$")"	##"	" ž"
(" " HZ" &")	" Z &	" Z *	%Z	(" "	#Z	\$"	' "	*"	" ž"
(" " HZ" (")	" Z (" ž\$	%Z	(" "	#Z	\$"	\$"	%	" ž"
(" " HZ" "")	" Z *	" ž(%Z	(" "	#Z	\$"	#'	S'	" ž"
(" " HZ"##")	" ž##	" žS'	%Z	(" "	#Z	%Z	(Z	#*	" ž"
(" " HZ#")")	" ž'	" ž%	%Z	(" "	#Z	' Z	(Z	#Sž	#(Z
(" " HZ#" (")	" ž(" ž%\$	%Z	(" "	#Z	#\$	&Z	#" Z	" ž'
(" " HZ\$" "")	" žS"	" ž&"	%Z	(" "	#Z	#\$	' Z	#" Z	" ž'

FZWd_ S^6 WdSfja` 5 ZSdž:Za V

Part number	-40	-20	0	25	40	50	60	70	85
(" " HZ" %")	#% .	## +.	# " .	+ \$.	* %.) %.	(& .	' ' .	& \$.
(" " HZ" &")	#% .	## +.	# " .	+ \$.	* %.) %.	(& .	' ' .	& \$.
(" " HZ" (")	#% .	## +.	# " .	+ \$.	* %.) %.	(& .	' ' .	& \$.
(" " HZ" "")	#% .	## +.	# " .	+ \$.	* %.) %.	(& .	' ' .	& \$.
(" " HZ"##")	#% .	## +.	# " .	+ \$.	* %.) %.	(& .	' ' .	& \$.
(" " HZ#")")	#% .	## +.	# " .	+ \$.	* %.) %.	(& .	' ' .	& \$.
(" " HZ\$" "")	#% .	## +.	# " .	+ \$.	* %.) %.	(& .	' ' .	& \$.